

fiberon® Cladding

Installation Instructions

For Fiberon Wildwood™ Cladding
Eden and Sahara Collections

1-800-573-8841 | cladding.fiberondecking.com

Cladding Boards and Accessories

Board Profiles



.75 in. x 11.25 in. (19.05 mm x 285.75 mm)
Lengths: 12 ft. (3.66 m)



.75 in. x 7.25 in. (19.05 mm x 184.15 mm)
Lengths: 12 ft. (3.66 m)



.75 in. x 6 in. (19.05 mm x 152.4 mm)
Lengths: 12 ft. (3.66 m), 16 ft. (4.88 m) and 20 ft. (6.1 m)

Fasteners

Other fasteners may be used as long as they meet the minimum requirements.



Cap-Tor® xd Deck Screws, minimum #9 - 2-½ in. (63.5 mm)
or equivalent composite deck screw.

General Guidelines

These instructions were prepared for installers with experience in the field of cladding, façade, siding and soffit installation.

- It is assumed the installer understands the tools required and how to properly use them.
- It is also required that the installer has thoroughly reviewed these instructions and those of accessory products.

Prior to installation, consult local building code / zoning officials, historic districts and HOAs regarding:

- Applicable requirements for rainscreen assemblies.
- Wind-load testing requirements.
- Historic districts that may regulate size, placement and type of cladding.

Ensure all installations employ accepted building practices and applicable codes and comply with local code and zoning requirements. Additional local or installation specific restrictions and requirements may apply.

Rainscreen systems require the creation of a minimum 3/8-in. (10 mm) ventilated drainage plane. Drainage plane assembly and specific component materials are outside the scope of our warranty and installation instructions. Consult manufacturers of those products.

Extreme heat conditions, such as concentrated / reflected light from glass, high-temperature lighting, pipes and proximity to cooking grills and fire pits pose potential damage to cladding boards used in rainscreen applications. Prior to installation, all concerns about potential damage and mitigation of risk, or claims resulting from these products, should be addressed with the manufacturers of such products.

Cladding boards may not be suitable for every cladding or rainscreen application. Determining the suitability for the intended use is not the responsibility of Fiberon.



WARNING: Drilling, sawing, or machining wood-composite products containing wood fiber can expose you to wood dust, a substance known to the State of California to cause cancer. Avoid inhaling dust generated from wood-composite products or use a dust mask or other safeguards for personal protection. For more information, go to www.P65Warnings.ca.gov.

Pre-Construction Considerations

Cladding boards feature a wood-grained embossing pattern with random color variations. To optimize the installed aesthetic, visually inspect and arrange boards in an intended assembled order prior to installation.

Boards should be laid out in the shade 30 minutes prior to their installation to allow the boards to acclimate to ambient temperature. To reduce temperature acclimation time, store the product in a location in which the temperature is comparable to the installation environment.

Cladding boards contract and expand in response to temperature changes. This dynamic needs to be addressed via proper gapping and fastening in the layout of window and door openings, terminations, corners and intersections with other cladding materials. When laying out boards for optimal utilization of materials, always take into account the side-to-side and end-to-end gapping requirements.

When laying out the installation, take appropriate steps to avoid the need to rip boards into very narrow profiles, such as when cutting around windows and doors.

Furring materials must be exterior grade and, for open-joint profiles, installations must be long-term UV stable to withstand direct sun and weather contact.

Design Considerations

- Plan your installation including board lengths, furring locations and color layout for best yield and finished appearance.
- Cladding boards may be installed horizontally, diagonally or vertically.
- Cladding boards may be installed on suitably engineered and fabricated structural members as a soffit or ceiling, following cladding installation instructions (refer to Soffit Addendum).
- Cladding boards may be installed on suitably engineered and fabricated structural members as an on-grade or above-grade screen façade without the weather-resistive barrier (WRB), provided all other installation requirements are met (refer to Screen Façade Addendum).
- If desired for cosmetic reasons, a sample of the material can be color-matched to an oil-based or acrylic-based paint to color exposed cut board ends. Note that this may need reapplication, depending on the environment in which the material is installed.

Pre-Installation Checklist

- ✓ Upon delivery, ensure the order is complete and has arrived in good condition. Fiberon is not responsible for the installation of a damaged product.
- ✓ Store cladding boards on a pallet on a flat surface, supported at both ends and at 2 ft. (minimum) intervals. Improper product storage may result in distortions visible after installation.
- ✓ Keep boards covered prior to installation to minimize exposure to dirt and cementitious / mineral dust.
- ✓ Determine furring / fastener placement in advance for optimal aesthetics.
- ✓ Furring creates a planar surface. Correct deviations prior to installation of cladding.
- ✓ Weather resistant barrier (WRB) and flashing are installed in accordance with manufacturer's instructions.
- ✓ Drainage plane is a minimum allowable space of 3/8 in. (10 mm) to a maximum allowable space of 3/4 in. (20 mm).
- ✓ Cladding is a minimum of 6 in. (152 mm) above soft grade and 2 in. (51 mm) above hard grade.
- ✓ Cladding will be installed a minimum of 1/4 in. (6.4 mm) below the bottom of the sheathing.
- ✓ Test fasteners for aesthetic acceptability and to familiarize yourself with their installation.

Best Practices

Installers are familiar with all installation requirements (spanning, gapping, fastening, etc).

- Always install cladding boards over a suitable substructure.
 - Shim furring as necessary.
 - Ensure the fastening surfaces are sound, flat and true (planar) prior to starting board installation.
 - It is strongly recommended to remove the old siding prior to the installation of Fiberon cladding boards.
 - Remember, your siding installation will be only as straight and stable as the substrate behind it.
- Always follow the gapping requirements.
 - Gapping is sufficient to allow for thermal expansion at every termination, transition and intersection.
 - Failure to gap properly will create consequences that may not be easily remedied.
- Anticipate and provide adequate clearances around penetrations and from hard and soft grades.
- Always use a fastener that is suitable for the job, especially in salt water / salt spray environments.
- For optimal results use surface fasteners made for composite boards.
 - Pre-drilling is always required for other types of fasteners.
 - Pre-drilling is always required for end fasteners and any board less than 3 in. (76.2 mm) in width.
- Test fasteners for installation method and acceptable aesthetic before beginning installations.
- Fasteners must be installed at a 90-degree angle to face of cladding.
- For single person installations, fasten boards from their center outward toward their ends.
- Routinely check cladding courses to ensure they are level.
 - Adjust for slight fluctuations in board width as you go.
 - Adjustments may be necessary to maintain level installation.
- Avoid seams installed directly above an opening in a wall.

What Not To Do

- X Never use cladding boards as structural elements.
- X Never install cladding boards in direct contact with building envelope components without a ventilating drainage plane.
- X Never attach cladding boards to structural members that are rotted, damaged or otherwise insufficiently strong for the application.
- X Never exceed maximum spans between furring strips (or their engineered equal).
- X Do not install fewer than the required amount of fasteners per structural attachment.
- X Do not install fasteners without first testing the aesthetic and deeming it acceptable.
- X Do not install fasteners closer than 1 in. (25.4 mm) from board edges.
- X Do not install fasteners closer than 1 in. (25.4 mm) from any board end.

Installation Process Overview

1. Install weather-resistive barrier (WRB).*
2. Install additional drainage flashing.*
3. Install drainage plane materials.*
4. Prep for trim layout.
5. Install trim.
6. Install cladding.
7. Finish details.

Details for suppliers who have tested Fiberon cladding boards with their product and supplied their product recommendations, installation instructions and technical materials can be found on our website: cladding.fiberon.com/product/compatible-components.

*Per manufacturer's instructions.

Gapping and Clearance Specifications

Gapping	If < 30 F (-1 C)	If > 31 F (0 C) and < 50 F (10 C)	If > 50 F (11 C) and < 70 F (21 C)	If > 70 F (22 C) and < 90 F (32 C)	If > 90 F (33 C)	Notes
End-to-End Required	1/4 in. (6.35 mm)	3/16 in. (4.76 mm)	1/8 in. (3.175 mm)	1/16 in. (1.5875 mm)	1/32 in. (0.79375 mm)	Improper gapping will potentially result in a wavy appearance or inconsistent gapping over time.
Edge-to-Edge Minimum	3/16 in. (4.76 mm)					Greater gaps are acceptable with open-joint profile boards but care should be taken to avoid creating a ladder effect.

Clearances	Minimum	Maximum	Notes
Drainage Plane front of WRB to back of cladding	3/8 in. (10 mm)	3/4 in. (20 mm)	Distance from WRB to back of cladding.
Edge-to-Structure Minimum	1/4 in. (6.4 mm)		Penetrations (standard) include intersecting walls, intersecting materials, pipes, supports, canopy anchors, etc.

Fastener Specifications

Fasteners	Open-Joint Board 1x6 (nominal)	Open-Joint Board 1x8 (nominal)	Open-Joint Board 1x12 (nominal)
Actual Board Dimensions	3/4 in. x 6 in. (19.05 mm x 152 mm)	3/4 in. x 7-1/4 in. (19.05 mm x 184 mm)	3/4 in. x 11-1/4 in. (19.05 mm x 285.75 mm)
Min. Fastener Size	<ul style="list-style-type: none"> For metal framing: minimum #9 -1-5/8 in. (41.28 mm) For 3/8 in. furring: minimum #9 - 2-1/2 in. - 2-3/4 in. (63.5 mm - 69.85 mm) composite deck screw. For 3/4 in. furring: minimum 2 3/4 in. -3 in. (69.85 mm - 76.2 mm) composite deck screw. 		
Fastener Quantity	2		
Fastener Spacing	16 in. OC (406.4 mm)		
Minimum from Edge or End	1 in. (25.4 mm)		
Notes	<ul style="list-style-type: none"> Screws must be installed at 90-degree angle to board. Toeing of fasteners will result in increased potential for board cracking and fastener pull-through over time and damage is not covered by warranty. It is best to use a fastener designed for composite board material. <ul style="list-style-type: none"> For best results, pre-drilling is always recommended and is required within 1 in. (25.4 mm) of board ends. Use the right fasteners for your desired aesthetic and framing components. <ul style="list-style-type: none"> Alternative furring materials and wall assemblies may require different fastener lengths. Metal and wood screws are available for use with composite boards. When using porous furring, drainage plane or other material types in your rain screen assembly, the use of longer composite fasteners may be required. Consult the fastener manufacturer for appropriate recommendations for your specific wall assembly requirements. <ul style="list-style-type: none"> Note that use of other types and lengths of fasteners should be reviewed by a licensed structural PE in the state of the application. #316 stainless steel is recommended in all areas with potential for or designated as salt spray zones (rust stains are not covered by Stain and Fade Warranty). 		

Best Practices - Weather-Resistive Barriers

Fiberon recognizes there are many high-quality WRB options currently available; however:

- The WRB used must be of sufficient quality and material specification for the application.
- A properly installed and flashed WRB is the primary water management defense in rainscreen applications.
- Your WRB decision should meet or exceed the project's needs relative to UV stability, water resistance, moisture infiltration and water vapor exfiltration.
- Choose a WRB with long-term UV resistance that is suitable for open-joint rainscreen applications.
- Consult with the WRB manufacturer for specifications, compatibility concerns and any special considerations.

Best Practices - Drainage Plane / Furring Materials

Fiberon does not manufacture products to create drainage plane materials but recommends the following:

- Furring may consist of:
 - Metal.
 - Wood or PVC boards.
 - Entangled nets with or without fabric.
 - Corrugated plastics.
 - Other products that meet or exceed the design requirements.
- Any products chosen must be of sufficient quality and material specification for the application.
 - If furring is the primary structural support of the weight of cladding, then it needs to be sufficiently strong to do so and the furring must be properly attached to building structure.
 - Metal or solid furring, adequately shimmed, may be the fastest way to achieve a planar surface on uneven walls.
- Porous furring is always recommended, but must meet the demands of the applications.
- Long-term UV-stability requirements should match or exceed cladding warranty duration.

Best Practices - Trim

Trim is an important design element in most rainscreen applications.

Fiberon does not manufacture engineered trim products but recommends the following:

- Trim must be of sufficient quality and material specification for the application.
- Cladding materials may be used to create prescriptive trim elements, generally consistent with such trim in wood cladding installations, but care should be taken to comply with all gapping, spanning and fastening requirements.
- Commercially available metal trim products are commonly used and suitable when installed correctly. Consult the engineered trim manufacturer for compatibility and any special considerations.
- Trim can also be fabricated on brakes, on-site, from appropriate raw materials (ex: coil stock).

Horizontal Installation

1 Preparing for installation.

- Prepare the wall for cladding installation by applying a quality WRB system inclusive of proper flashing at corners and around penetrations in the wall (i.e. windows and doors).

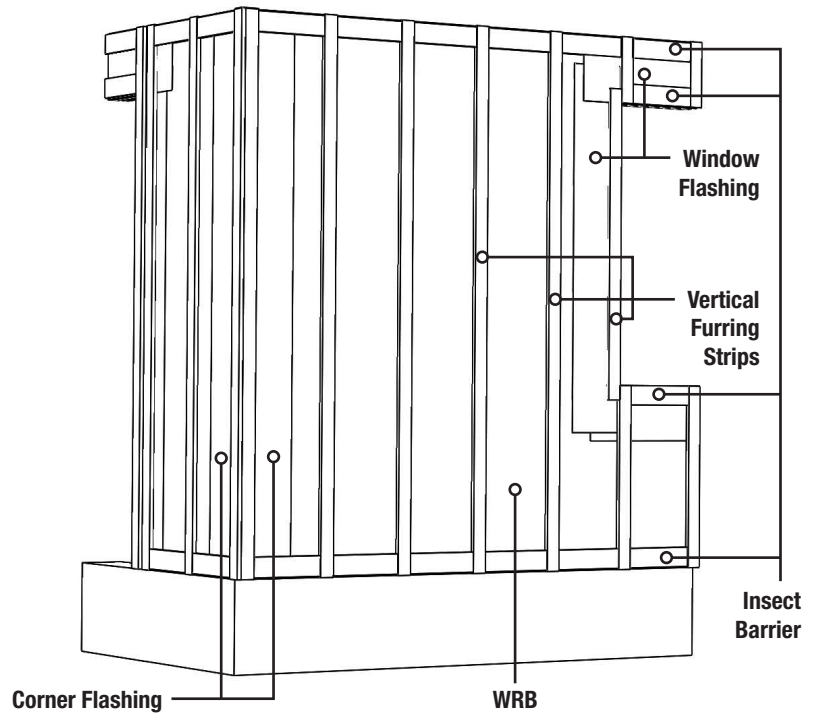

2 Chalking a level line.

- Chalk a level line based on the lowest corner of the structure, or lowest point where siding will be installed, particularly in regard to remodels.
- The line must be a minimum of 6 in. (152.4 mm) above soft grade and 2 in. (50.8 mm) above hard grade. Where boards are installed above a roof system (as in a turn gable), allow a minimum of 2-in. (50.8 mm) space between the roof surface and the bottom of the board. Refer to the Gapping Requirements and Specifications table.
- Secure the furring strips with the bottom of the furring strip starting at the chalk line, and secured no more than 16-in. (406.4 mm) on-center (OC).

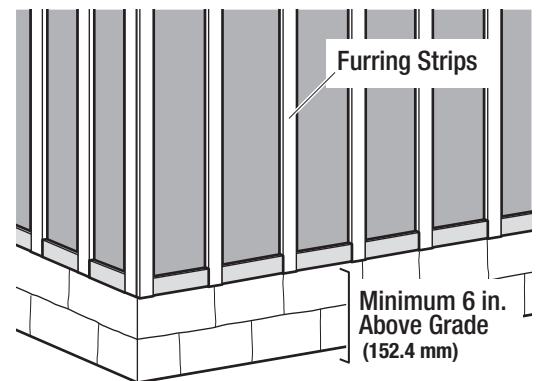

3 Installing the first course.

- Measure and cut board to length. For starter boards, allow for seams on shared 1 in. x 4 in. (25.4 mm x 102 mm) minimum, or sistered 1 in. x 3 in. (25.4 mm x 76.2 mm) furring strips.
- Ensure the board is level and secure it. Refer to the Gapping and Clearance Specifications on page 5 and Fastener Specifications on page 6.

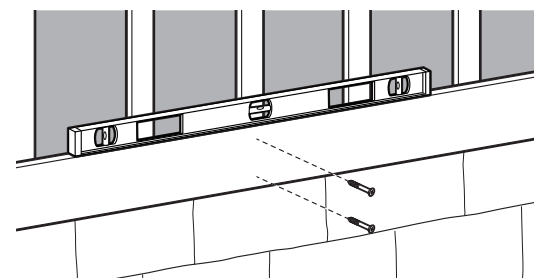

Horizontal Installation (continued)

4 Securing the first boards.

- Secure the boards outward toward the board ends using two screws per furring strip. Check often to ensure the boards remain level.

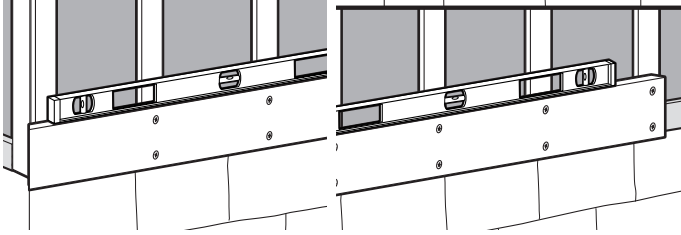

5 Securing the board ends.

- Secure the end of the board not closer than 1 in. (25.4 mm) from the board end and not closer than 1 in. (25.4 mm) from the board edge. See gapping requirements on page 5.
- Pre-drill end fasteners to prevent stress cracking.
- In courses requiring more than one board, butt the next board to the previous board end. See gapping requirements on page 5.

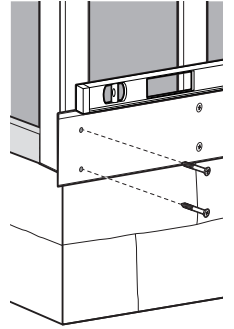

6 Installing the second course.

- Using spacers (minimum 3/16 in. or 4.76 mm) for consistent side-to-side gapping, secure the next course starting from the approximate center of the board and working outward.
- Continue checking to ensure courses are level. Adjustments may be necessary to accommodate board width variation.

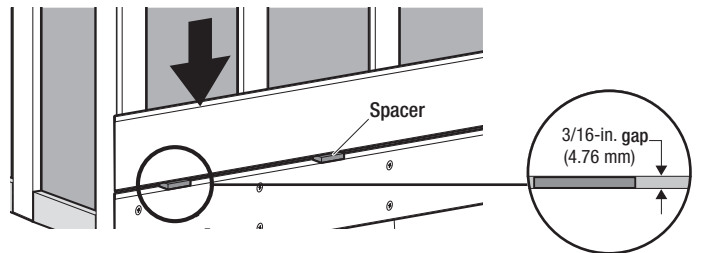

7 Installing the remaining courses.

- As additional courses are added, stacked, staggered or random seams are acceptable.



NOTE: Avoid having a seam over an opening in the wall.

- If possible, do not use boards that do not span the length of three furring strips at a minimum (approximately 32 in. (812.8 mm)).
- You must install fasteners perpendicular to the board. Do not angle fasteners. At seams, it may require sistering of furring strips (image 2).
- Notch boards around openings in the wall. Always pre-drill holes in boards 3-in. (76.2 mm) wide or less.

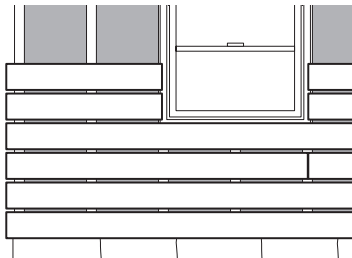

Image 1

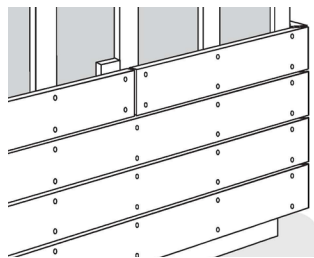

Image 2

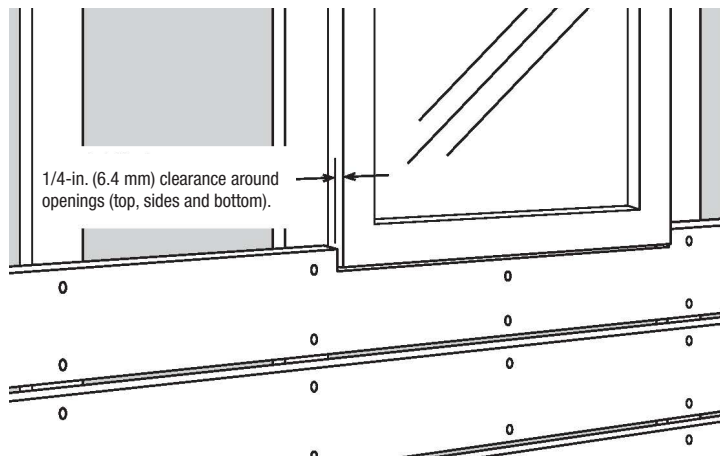
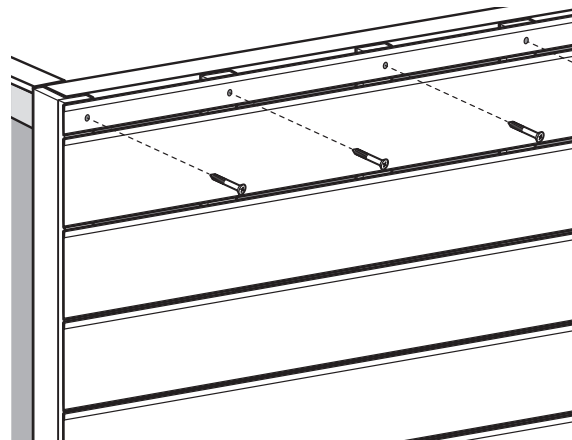

Image 3

8 Finishing under soffit

- At the top of the wall, it may be necessary to rip the board to the required width.
- Always pre-drill boards 3-in. (76.2 mm) wide or less.



9 Continuing the installation to adjoining walls.

- Move to adjoining walls, ensuring courses are level with the previous wall. Frequently check that courses are level at the corners to ensure boards are all aligned.



NOTE: When installing corner boards and framing out windows, additional furring may be required to provide sufficient fastening surface. Build out the corner boards and window / door trim at least 1/4 in. (6.35 mm) beyond the cladding. Corner boards should extend 1/2 in. (12.7 mm) to 1 in. (25.4 mm) lower than the siding courses.

- At corners and all intersections with different planes or materials, ensure proper gapping, fasteners and fastener placement. Refer to the Furring, Fastener and Gapping Specifications sections.

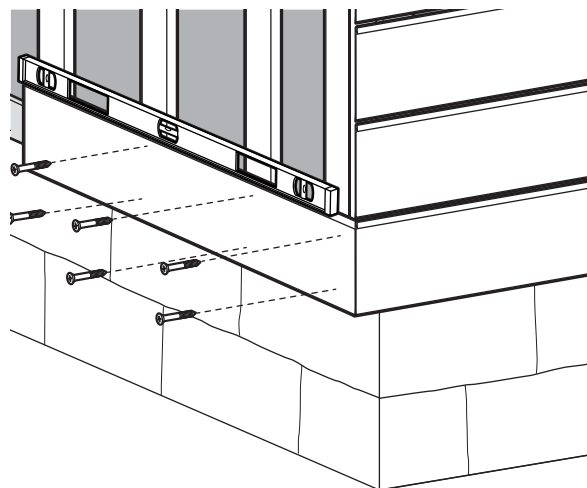

10 Using Z-flashing.

- For walls exceeding the available length of the boards, or for creating a decorative break, separate the lower wall from the upper with a Z-flashing. Allow a 1/4-in. (6.35 mm) clearance between the top of the lower boards to the underside of the Z-flashing. Maintain approximately 1/2-in. (12.7 mm) clearance between the Z-flashing and the start of the upper boards.

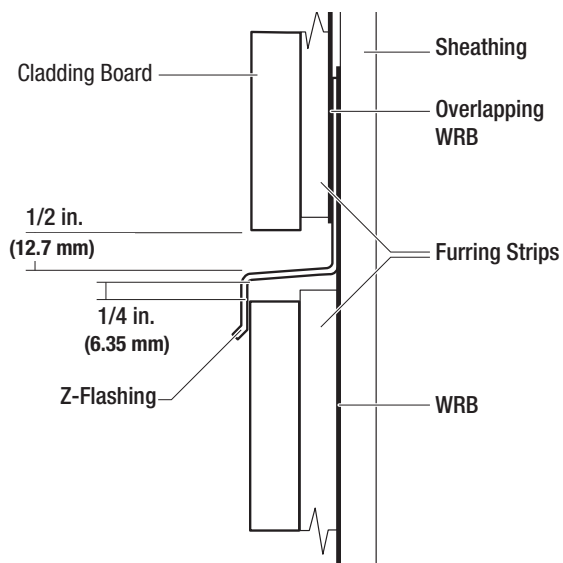

45-Degree Diagonal Installation

1 Installing diagonally.

Cladding boards can be installed up to 45 degrees diagonally.

To install cladding diagonally:

- Secure furring strips vertically not more than 12 in. (304.8 mm) OC. Extra shimming may be required as necessary (i.e. supporting the starting piece).
- Secure cladding boards, starting from the highest end of the board, with two surface fasteners per furring strip. Allow 1 in. (25.4 mm) from edges, 1 in. (25.4 mm) from ends.

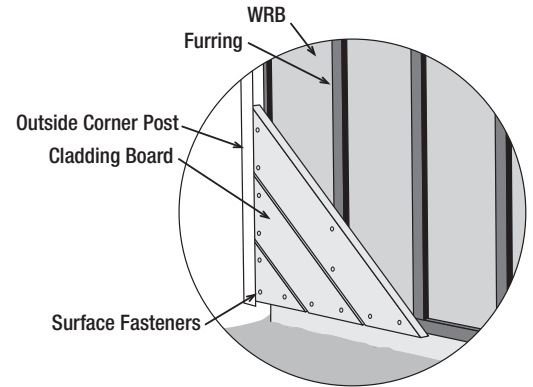

Vertical Installation

1 Installing the first course.



NOTE: For a centered appearance, you may need to rip two equal boards.

- Secure furring strips horizontally not more than 16 in. (OC).
- Measure and cut the first board. The board should extend 1/2 in. (12.7 mm) to 1 in. (25.4 mm) below the furring /strapping, and be 1/4 in. (6.35 mm) clear from the soffit. Starting from the top and working downward, secure using two minimum #9 gauge x 2-1/2 in. (63.5 mm) composite deck screws placed a maximum of 16 in. OC, not closer than 1 in. (25.4 mm) from board edges, and 1 in. (25.4 mm) from board ends.
- Working downward, secure the board into each furring / strapping, using two minimum #9 gauge x 2-1/2 in. (63.5 mm) composite decking screws. Do not exceed 16 in. (406.4 mm) OC. Ensure that you maintain plumb.

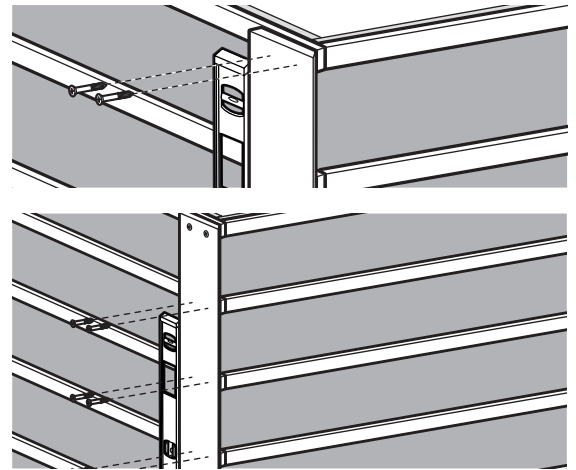

2 Installing the second course.

- Using 3/16-in. (4.76 mm) spacers, secure the next course starting from the top and working downward.

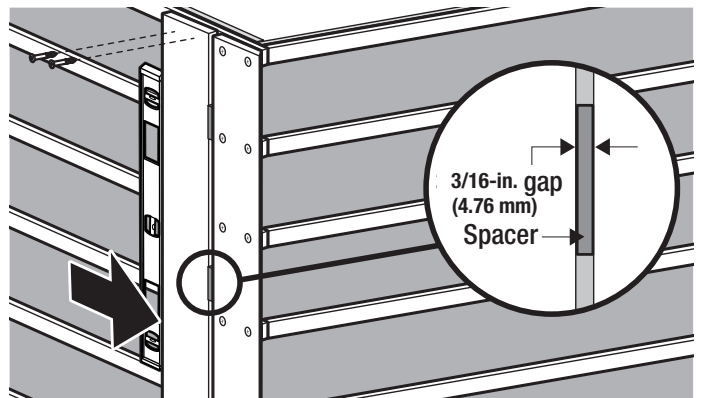

Vertical Installation (continued)

3 Continuing the installation.

- Notch boards for openings in the wall. Always pre-drill holes in widths 3 in. (76.2 mm) or under, and secure with one minimum #9 gauge x 2-1/2 in. (63.5 mm) composite deck screw.

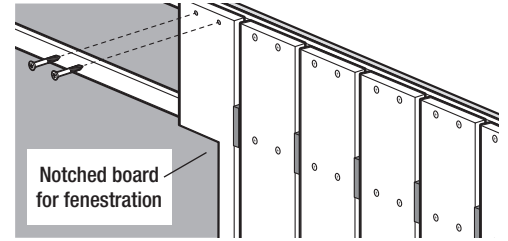

4 Using Z-flashing.

- For walls exceeding the available length of the boards, or for creating a decorative break, separate the lower wall from the upper with a Z-flashing. Allow a 1/4-in. (6.35 mm) clearance between the top of the lower boards to the underside of the Z-flashing. Maintain approximately 1/2-in. (12.7 mm) clearance between the Z-flashing and the start of the upper boards.

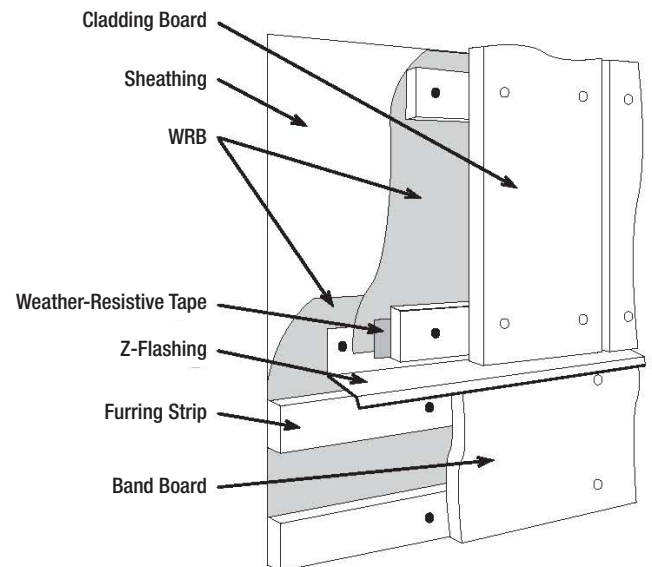
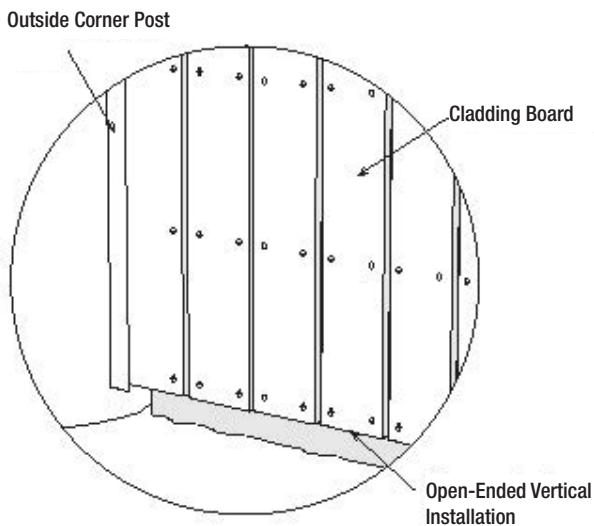
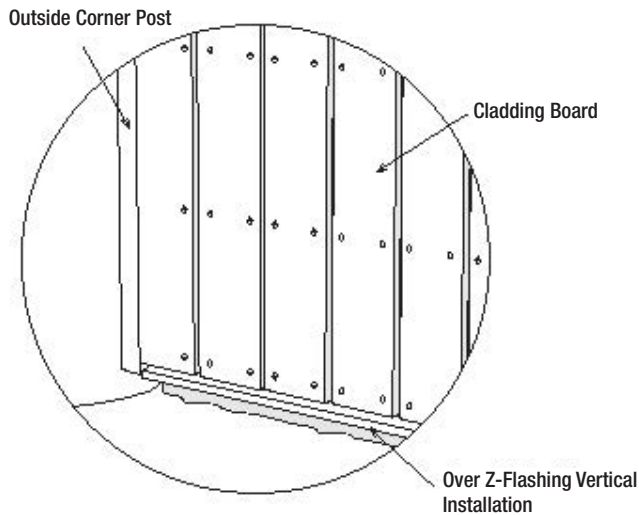
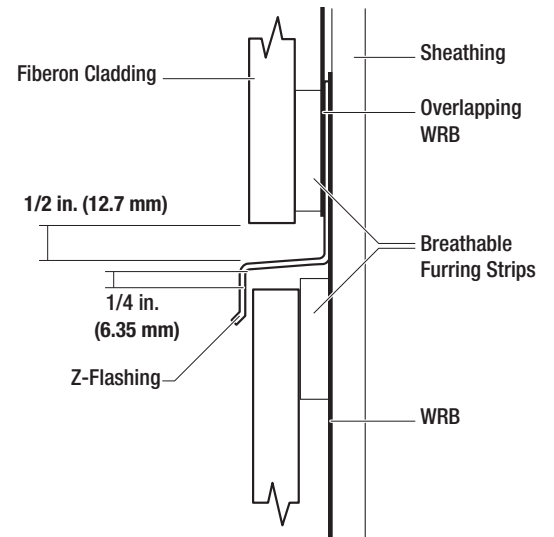

Addendum: Screen Façades and Soffit

SCREEN FAÇADE DEFINITION*:

Non-structural façade disguising the realities of form, size and structure of a building behind.

Screen Façade Applications

Installation of cladding boards as a screen façade is permitted when installation is consistent with Fiberon’s installation instructions. Fabrication of the structural plane, the appropriateness of materials used in its construction and the attachment of the structural plane to other structures, whether on grade or above grade, is outside the scope of our instructions and warranty.

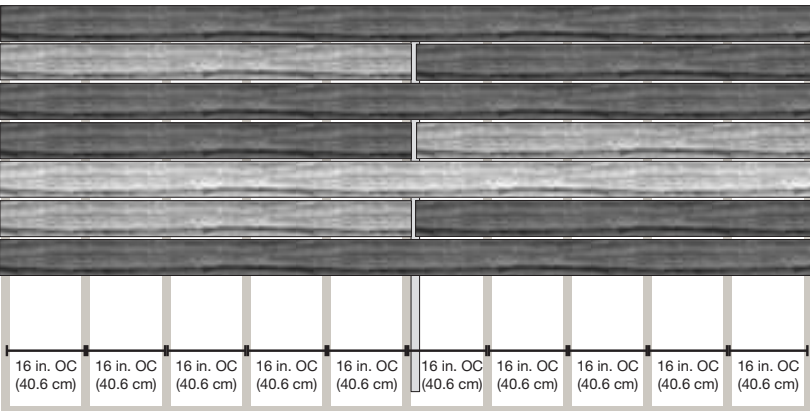
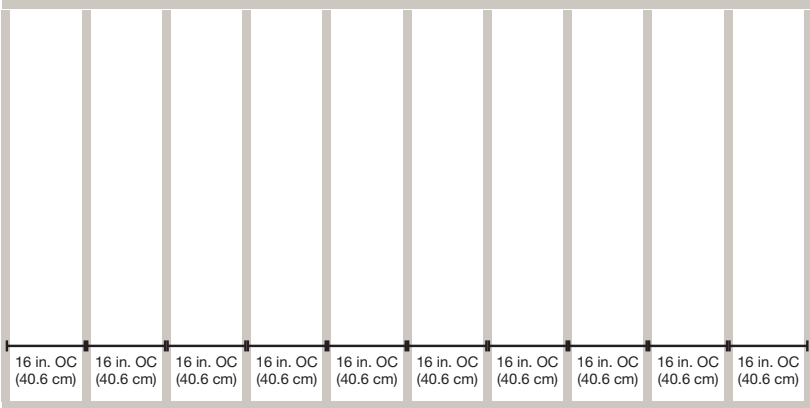

Structural Plane

- **STRUCTURE** The sheathed wall leading up to being covered.
- **MATERIALS** Outside the scope of Fiberon® specifications, instructions and warranty.
- **SPACING** Structural members spaced 16 in. (406.4 mm) OC (or less).

Warranty

- Fiberon Wildwood composite cladding is backed by a 50-year warranty covering stain, fade and performance in residential and commercial applications.
- Warranty details may be found at cladding.fiberondecking.com/technical/warranty.

*A Dictionary of Architecture and Landscape Architecture 2000.
 **The Oxford Dictionary of Architecture (3 ed.)

SOFFIT DEFINITION:**

Visible underside of an arch, balcony, beam, corona, cornice, vault or any exposed architectural element.

Soffit Applications

Installation of cladding boards are permitted as a decorative component in soffit type applications when installation is consistent with Fiberon’s installation instructions for cladding. Fabrication of the structural plane of attachment, the appropriateness of the materials used in its construction, and the ventilation requirements for the particular installation are outside the scope of our instructions and warranty.





Beautiful outdoor living built for life.®

1-800-573-8841

cladding.fiberondecking.com

Retain this manual for future use.

Visit cladding.fiberondecking.com/technical/literature for the most up-to-date installation requirements.